

PROVISION **ISR**®

Now you can see!



- Professional HD PTZ Camera

USER MANUAL for ZP-20A-2(IR)
for ZE-20A-2(IR)

Package Contents:

Item ZP-20A-2(IR)	Qty.
ZP-20A-2(IR)	1
Wall Bracket	1
Hinge Pin	1
Rubber Seal	1
AC power supply	1
Wall Screws	4
PM8*25 socket head screws	1
Allan Key	1

Item ZE-20A-2(IR)	Qty.
ZE-20A-2(IR)	1
Wall Bracket	1
DC power supply	1
Wall Screws	4
PM8*25 socket head screws	1
Allan Key	1

Table of Contents:

1 General Instructions:	3
1.1 Safety Instructions:	3
1.2 Warnings:	3
2 Features:	4
2.1 Product Picture:	4
2.2 Product Features	4
2.3 Specifications:	5
3 Installation Site Preparations:	7
3.1 Tool List:	7
3.2 Installation Preparation:	7
3.3 Output mode setting:	6
3.4 Product dimension:	7
4 Setup of the OSD Menu:	8
4.1 Display Boot-UP Info.	8
4.2 Enter the OSD Menu:	9
4.3 SYSTEM Menu:	10
4.5 Advanced Camera Menu:	18
APPENDIX I Shortcuts Key Chart:	21
APPENDIX II Trouble Shooting:	21

1 General Instructions:

1.1 Safety Instructions:

- ◆ Make sure to read the user manual before using the camera.
- ◆ Always follow national and local safety codes during the installation.
- ◆ Only a qualified and experienced person can carry the installation and maintenance for this camera.
- ◆ Use reliable tools.
- ◆ Make sure that the environmental conditions meet the installation requirements for this product.
- ◆ Please check the space and toughness of the installation surface before installation. It should be able to bear 4 times the weight of the camera and its accessories.

1.2 Warnings:

- ◆ Do not install this speed dome in hazardous places where combustible or explosive materials are stored or used.
- ◆ Do not install on a platform that suffers from constant vibrations.
- ◆ Make sure no object or fluid substances get inside the unit.
- ◆ ZP-20A-2(IR) runs on AC24V and ZE-20A-2(IR) runs on DC12V. Do not connect it to a different voltage.
- ◆ Do not turn the power on before installation is complete.
- ◆ Do not disassemble any part of the camera.
- ◆ Use a soft towel to clean the down the lenses when necessary, do not use caustic detergent.
- ◆ To protect the image sensor, avoid facing the camera directly into a strong light.
- ◆ To prevent damage, do not drop the unit or expose to strong shocks or vibrations.
- ◆ Make sure no object is blocking the unit's full range of motion.

2 Features:

2.1 Product Picture:



ZP-20A-2(IR)



ZE-20A-2(IR)

2.2 Product Features (Items marked with * are only available in ZP-20A-2(IR) Pro solution)

- ◆ Alarm I/O: 1 Input/ 1 Output*
- ◆ CoC Support
- ◆ 4 in 1 (AHD/TVI/CVI/CVBS)
- ◆ Adaptive PELCO-P/D protocol.
- ◆ Memory recall.
- ◆ Real-Time-Control: call any functions at any time.
- ◆ Support 255 preset positions.
- ◆ English OSD menu.
- ◆ Proportional zoom.
- ◆ Auto flip function.
- ◆ Built-in lightning proof and surge proof protection.
- ◆ Advanced step motor for smoother movement.
- ◆ Support Tour 4 groups, 8 Auto scan, 4 patterns, and 360°continuous scan and 360° intermittent scan.
- ◆ The upper dome adopts 7" aluminum alloy structure for better

magnetic shield and heat radiation.

- ◆ The underpart dome adopts full metal class points bin type design for fast heat dissipation and anti-mist, non-interference light source images and long life span IR light.
- ◆ Integral Junction box for easy installation*

2.3 Specifications:

Model	ZP-20A-2(IR)	ZE-20A-2(IR)
Sensor	1/2.8" CMOS	
Resolution	2MP- 1920*1080	
Optical Zoom	X20 (4.9-97MM)	
Digital Zoom	No	
Minimum Focus Distance	1.5M	
Horizontal Angle of View	H:57 (Wide) to 4 (Tele) V:33.5 (Wide) to 2 (Tele)	
Sync System	Internal	
Min. Illumination	0.01Lux (0 Lux with IR ON)	
Day & Night	Auto/Manual/Night	
S/N Ratio	>50db	
Focus	Auto/Manual/One-Push	
Auto Gain	Auto/Manual	
Wide-D	Yes	
White Balance	ATW/Manual/Outdoor/Indoor/AWB/AWC	
BLC	On/Off	
Shutter Speed	1/ 50 ~1 / 10000	
Sense Up	No	
Noise Reduction	3D-DNR	

Flip	ON/OFF	
Picture Freeze	No	
Iris	Auto	
Power Supply	AC24V±5%, 3A	DC12V, 2A
Sync system	Internal Sync	
Language	English	
Signal Output	4 in 1 AHD/TVI/CVI/CVBS + PAL/NTSC	
IR Distance	100 IR LED Array	
Pan Speed	0.01°~350°/s (Max. Preset Speed)	0.01°~60°/s (Max. Preset Speed)
Tilt Speed	0.01°~120°/s (Max. Preset Speed)	0.01°~30°/s (Max. Preset Speed)
Pan Range	0°~360°(Continuous)	
Tilt Range	0°~90° (180° auto flip)	
Presets	255	
Preset Accuracy	<±0.1°	
Tour	4Groups	
Pattern	4	
Auto-scan	8	
Protocol	CoC / RS-485	
Communication	CoC / PELCO-D/P	
Baud Rate	2400bps、4800bps、9600bps	
Address	1-255 (Software)	
Work Temperature	-20 °C +50°C	
Work Humidity	<90%	
Weight	3.25Kg	

3. Installation Site Preparations:

3.1 Tool List:

- | | |
|-------------------------|--------------------------|
| (1) Screws* | (2) Monkey wrench |
| (3) Philips screwdriver | (4) Straight Screwdriver |
| (5) Wire stripper | (6) Socket head wrench |
| (7) Electric drill | (8) Hammer |
| (9) BNC connector | (10) BNC Clamp |

*Included in the kit

3.2 Installation Preparation:

- (1) Check the space and toughness of the site and make sure that the environmental conditions meet the installation requirements for this product.
- (2) The installation surface should be able to bear 4 times the weight of the PTZ and its accessories.

3.3 Output Mode Setting:

- (1) Default Settings: AHD, PAL system

This output can be changed via the controller (Even if the user cannot gain a video output from the unit due to output incompatibility)

- (2) Set your controller/DVR PTZ Settings to the Camera's Default Communication Settings: **Protocol: CoC / PELCO-D, address: 1 (Unless user changed it by the DIP switch configuration), baud rate: 2400.**
- (3) In order to change the output type follow the instructions below:

AHD/TVI/CVBS Command			
Set #85 preset, Please note: you will have to use “Save Position” or delete and recreate the preset if you need to use it more than once – AS it is “set” action.	Call the preset number of the desired video type signal: e.g. “14” for CVBS/NTSC	N=1	AHD
		N=2	TVI
		N=3	CVI
		N=4	CVBS

CVI Command			
Set #50 preset, Please note: you will have to use “Save Position” or delete and recreate the preset if you need to use it more than once – AS it is “set” action.	Call the preset number of the desired video type signal: e.g. “14” for CVBS/NTSC	N=1	AHD
		N=2	TVI
		N=3	CVI
		N=4	CVBS

3.4Product dimension:

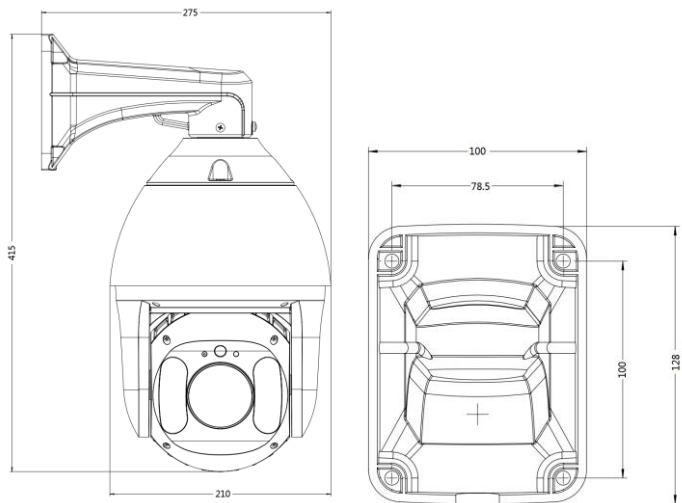

4. Setup of the OSD Menu:

4.1 Display Boot-UP Info.

Before installation please check the protocol, baud rate, address, and RS485 data cable. **Default Settings: Protocol: PELCO-D, address: 1, baud rate: 2400.**

VERSION: VR210P-306
SIGNAL:AHD PAL
PROTOCOL: PELCO P D
BAUD RATE: 2400
CAMERA ID: 001
TEMP: 36
STATUS:OK

4.2 Enter the OSD Menu:

While the camera is in standby condition, call preset 95 (“Call” + 95 + “Enter”) in order to display the main menu. Use the Up/Down direction to select the item or start the configuration. Use the Right key to confirm and left the key to exit the current setting.

The Main menu as follows:

INFORMATION
DOME SETTINGS
MOTION
RESTART
FACTORY DEFAULTS

EXIT

4.3 SYSTEM Menu:

<Main Menu> → <INFORMATION>

INFORMATION
DOME SETTINGS
MOTION
RESTART
FACTORY DEFAULTS
EXIT

The user can check the dome system information as required. The system information includes Version, dome address, baud rate, temperature, voltage.

4.3.1 INFORMATION

INFORMATION
VERSION: VR210P-306
ADDRESS:001
BAUDRATE:2400
TEMPERATURE:37
VOLTAGE:11.6V
BACK EXIT

4.3.2 DOME SETTING

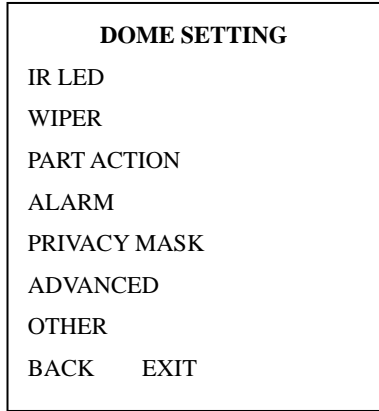

4.3.2.1 IR LED

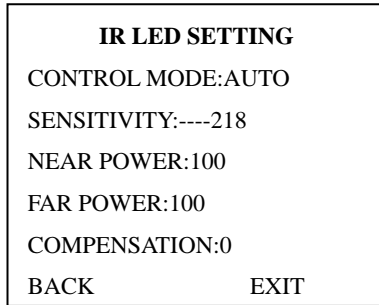

The user can open and close the IR LED manually and set up the IR LED work mode under this OSD mean. (Under normal operation mode, the user can press IRIS OPEN and IRIS CLOSE to adjust the IR LED power):

- 1) control mode:

AUTO	IR LED will be opened or closed automatically according to the light conditions.
ON	IR LED forcedly open
OFF	IR LED forcedly close
CAMERA	IR LED status (Open/Close) will be synchronized with Camera day and night switching

2) Sensitivity:

Users can manually set the sensitivity from 1-10. The smaller the number is, the lower light of the environment will be when the IR LED on.

3) NEAR POWER: 100

4) FAR POWER: 100

5) COMPENSATION: 0-50

4.3.2.3 Park Action

PARK ACTION	
TIME: 1MIN	
ACTION:NONE	
BACK	EXIT

Users can set the parking time and action.

1) Time: 1MIN/2MIN/3MIN

2) Action: NONE / patter1 / Tour1 / Scan1 / Preset1

4.3.2.4 ALARM (Only available for ZP-20A-2(IR))

ALARM SETTING

ALARM NO:1
CONTACT:NO
ALARM MODE:OFF
ACTION:NONE
ALARM OUT:OFF

4.3.2.5 ADVANCED

ADVANCED

FOCUS MODE: PUSH
FOCUS LIMIT:3M
(DOME SPEED)
(TILT ANGLE)
BACK EXIT

4.3.2.5.1 <ADVANCED> → <DOME SPEED SETTING>

DOME SPEED SETTING

DOME SPEED: 180
BACK EXIT

4.3.3 OTHERS

<p style="text-align: center;">OTHERS</p> <p>TEMP MODE:AUTO</p> <p>FAN ON TEMP:50</p> <p>AUTO FLIP:ON</p> <p>STOP TIME:30 SEC</p> <p>MENU OFF:5MIN</p> <p>DISPLAY:OFF</p> <p>(AZIMUTH ZERO)</p>
--

The user can set up TEMP MODE, INTERNAL FAN, AUTO FLIP, STOP TIME, MENU OFF here under the menu of "OTHERS"

1)TEMP MODE: To set up the control mode of dome fans and heaters. It includes three modes of AUTO, FAN HIGH SPEED, and FAN LOW SPEED.

2)FAN ON TEMP: To set up the temperature that Fan start work

3)AUTO FLIP: When the camera tilts downward and goes just beyond the vertical position, the camera will rotate 180 degrees. The user can press IRIS OPEN to enter and choose to turn on/off this function.

4)STOP TIME: To set up the time that dome will stop after receiving the last command. Options include 5 / 15 / 30 / 60 Sec.

5)MENU OFF TIME: To set up the time that the OSD menu is off when no operations. Options include 1 / 2 / 5 / 10 min.

4.3.4MOTION

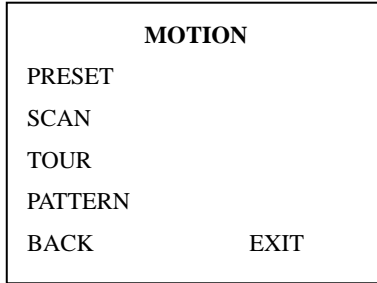

The user can set up 4 motion detection scenes under this menu.

- 1)PRESET: The dome supports 255 presets.
- 2)SCAN: The dome supports 8 groups of the auto scan.
- 3)Tour: The dome supports 4 groups of the cruise.
- 4)PATTERN: The dome supports 4 pattern tours and each pattern cover at
- 5)most 10 Minutes of 500 commands.

4.3.4.1 PRESET

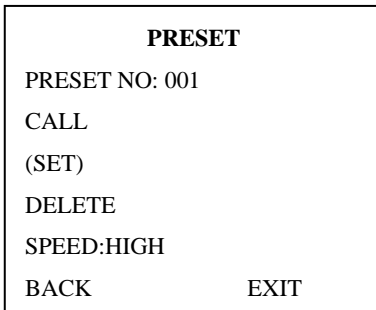

The dome supports 255 presets. Please check the following steps to set up a preset.

- 1) PRESET NO.: Move the cursor here and press IRIS OPEN to enter the setup of Preset Number. Move the joystick to select a preset number (1-64 and 100-255) and press IRIS OPEN to confirm.

- 2) <SET>: Move the cursor here and press IRIS OPEN to enter. Move the dome to a defined position as a preset point and press IRIS OPEN to save the preset position.
- 3) CALL: Move the cursor here and press IRIS OPEN to call up the current preset.
- 4) DELETE: Move the cursor here and press IRIS OPEN to delete the current preset.
- 5) SPEED: Move the cursor here and press IRIS OPEN to set up the preset call-up speed of LOW, MID and HIGH.

4.3.4.2 SCAN

SCAN	
SCAN NO:001	
START	
(LEFT LIMIT)	
(RIGHT LIMIT)	
SCAN SPEED:10	
BACK	EXIT

The dome supports 8 groups of auto scan. Please check the following steps to set up a scan.

- 1)SCAN NO.: Move the cursor here and press IRIS OPEN to enter the setup of SCAN Number. Move the joystick to select a preset number (1-8) and press IRIS OPEN to confirm.
- 2)TITLE: Move the cursor here and press IRIS OPEN to enter the setup of SCAN Title. Check the detailed above in DOME TITLE settings.
- 3)<LEFT LIMIT>: Move the cursor here and press IRIS OPEN to enter. Move the dome to a defined position as the left limit and press IRIS OPEN to save

this left boundary.

4)<RIGHT LIMIT>: Move the cursor here and press IRIS OPEN to enter. Move the dome to a defined position as the right limit and press IRIS OPEN to save this right boundary.

5)START: Move the cursor here and press IRIS OPEN to start the current scan.

6)SCAN SPEED: Move the cursor here and press IRIS OPEN to set up the scan speed ranging from 1-10.

4.3.4.3 TOUR

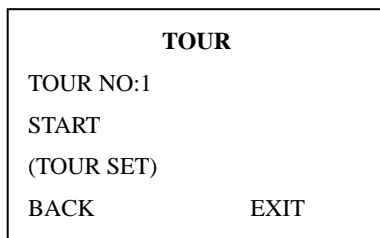

The dome camera will run repeatedly as the given sequence of presets at certain dwell time by one command. Max. 4 tours available (16preset/tour).

1)TOUR NO: Set the current tour number from 001~004.

2)DWELL: Set the default dwell time from 000~255 seconds for each preset. Users can still set independent dwell time for each preset when editing the tour.

3)EDIT: Edit presets and corresponding dwell time on a tour.

4.3.4.4 PATTERN

PATTERN	
PATTERN NO:1	
START	
(SET)	
DELETE	
BACK	EXIT

The dome supports 4 pattern tours and each pattern cover at most 10 Minutes of 500 commands. Please check the following steps to set up a pattern.

- 1) PATTERN NO.: Move the cursor here and press IRIS OPEN to enter the setup of Pattern Number. Move the joystick to select a pattern number (14) and press IRIS OPEN to confirm.
- 2) START: Move the cursor here and press IRIS OPEN to start the current pattern tour.
- 3) <SET>: Move the cursor here and press IRIS OPEN to enter. Move the dome up/down/left/right, make the zoom in/out and press IRIS OPEN to save the pattern tour.
- 4) DELETE: Move the cursor here and press IRIS OPEN to delete the current pattern tour.

4.5 Advanced Camera Menu:

For advanced Menu, Call preset #69.

PLEASE NOTE: Scrolling and changing values in the advanced menu is done with different controls:

- 1) The controller joystick has no effect.
- 2) Scrolling up and down is done by pressing IRIS+/IRIS-
- 3) Changing Values of the selected feature is done by pressing ZOOM+/ZOOM-

IMPORTANT!!! Changing any values the advanced menu might result in the camera malfunctioning

OSD-DISP	ON
D&N	AUTO
MIRROR	OFF
AGC	15
BRIGHT	40
CONTRAST	0
SHARPNESS	5
SAT	42
WDR	AUTO
2D-NR	1
3D-NR	2
BLC	OFF
WB	ATW
RGAIN	00
BGAIN	00

- <OSD-DISP >: Do Not Change
- <ADDR-DISP>: Do Not Change
- <D&N>: Do Not Change
- <MIRROR>: Turning Mirror effect ON/OFF
- <AGC>: changing the value of AGC
- <BRIGHT>: Changing the brightness value.
- <CONTRAST>: Changing the contrast value.
- <SHARPNESS>: Changing the sharpness value.
- <SAT>: Changing the saturation value.

- <WDR>: Turning Digital WDR effect ON/OFF
- <2D-NR>: Adjusting the level of 2D-NR noise reduction
- <3D-NR>: Adjusting the level of 3D-NR noise reduction
- <BLC>: switching OFF/ON.
- <WB>: White Balance is normally compensated for by the automatic white balance gain control. In some lighting conditions, the user may want to manually adjust the red and blue settings for optimal viewing. There are 6 options:
 - [AUTO]: Auto White Balance (default setting).
 - [ATW]: Auto track White Balance.
 - [PUSH]: Once touch White Balance
 - [OUTDOOR]: Suitable for outdoor use.
 - [INDOOR]: Suitable for indoor use.
 - [MANUAL]: Manually set the red and blue values
 - <BGAIN>: Set the blue value (Only effective if WB is set to Manual)
 - <RGAIN>: Set the red and value (Only effective if WB is set to Manual)
 - <DE-FOG>: Change the level of defog effect.
 - <OUTPUT>: Manually set the output between AHD / TVI / CVBS
 - <FORMAT>: Manually set the output between 25&30 (PAL/NTSC)
 - <ZOOM>: Do Not Change.
 - <FOCUS>: Do Not Change
 - <F-RANGE >: Do Not Change
 - <RESET >: Reset All settings to factory Default

APPENDIX I Shortcuts Key Chart:

AHD/TVI/CVBS Command			
Shortcut Key	Function (Set Preset)		
Set #84preset	Proportional P/T OFF		
Set #85preset, Call N	Call the preset number of the desired video type signal:	N=1	AHD
		N=2	TVI
		N=3	CVI
		N=4	CVBS
Set # 89preset	Delete all presets		
Set #90 preset	Set left limit Position		
Set #91preset	Set right limit Position		
Set #92 preset	Delete left/right limit		
Set #93preset	Dome restart		
Set #94 preset	Restore Factory Setting		
Set #95preset	Open main menu		
Set #96 preset	Park OFF		
Set #97 preset	60S Park time ON		
Set #98preset	120S Park time ON		
Set #99 preset	scan and tour scan speed is automatic		
Set #100 preset	scan and tour scan speed is high, 15°/sec		
Set #101preset	scan and tour scan speed is middle, 10°/sec		
Set #102preset	scan and tour scan speed is low, 5°/sec		
Set #103 preset	Record Pattern scan 1		
Set #104 preset	Record Pattern scan 2		
Set #105 preset	Record Pattern scan 3		
Set #106 preset	Record Pattern scan 4		
Set #107 preset	Set cruise 1		

Set #108 preset	Set cruise 2
Set #109 preset	Set cruise 3
Set #110 preset	Set cruise 4
Set #111 preset	Set color-to-black function
Set #112 preset	the preset-dwell: 0S
Set #113preset	the preset-dwell: 5S
Set #114preset	the preset-dwell: 10S
Shortcut Key	Function (Call Preset)
Call #67preset	Change system to PAL
Call #68preset	Change system to NTSC
Call #69 preset	Open Advanced Settings menu
Call #70 preset	Preset Error Correction
Call #71 preset	Proportional P/T ON
Call #72 preset	Start Cruise scan and switch the cruise scan direction
Call #73 preset	Start Pattern 1
Call #74 preset	Start Pattern 2
Call #75 preset	Start Pattern 3
Call #76 preset	Start Pattern 4
Call #77 preset	Call cruise 1 (default number 1~16 preset)
Call #78 preset	Call cruise 2 (default number 17~32 preset)
Call #79 preset	Call cruise 3 (default number 33~48 preset)
Call #80preset	Call cruise 4 (default number 49~64 preset)
Call #81 preset	Camera IR-CUT switch
Call #82 preset	Call all valid presets cruise
Call #83 preset	Call 360° scan
Call #95preset	Open main menu (Same response as "Set")
Call #95preset	Open main menu (Same response as "Set")

CVI Command			
Shortcut Key	Function (Set Preset)		
Set #50preset, Call N	Call the preset number of the desired video type signal:	N=1	AHD
		N=2	TVI
		N=3	CVI
		N=4	CVBS
Set #51preset	Proportional P/T OFF		
Set # 54preset	Delete all presets		
Set #55 preset	Restore Factory Setting		
Set #56 preset	Park OFF		
Set #57 preset	60S Park time ON		
Set #58preset	120S Park time ON		
Set #59preset	scan and tour scan speed is high, 15°/sec		
Set #60preset	scan and tour scan speed is middle, 10°/sec		
Set #61preset	scan and tour scan speed is low, 5°/sec		
Set #62preset	Set color-to-black function		
Set #63preset	the preset-dwell: 0S		
Set #64preset	the preset-dwell: 5S		
Set #65preset	the preset-dwell: 10S		
Shortcut key	Function (Call preset)		
Call #50preset	Camera IR-CUT switch		
Call #51preset	Call all valid presets cruise		
Call #52preset	Open main menu (Same response as "Set")		
Call #53 preset	Open Advanced Settings menu		
Call #54 preset	Preset Error Correction		
Call #55 preset	Proportional P/T ON		
Call #56 preset	Start Cruise scan and switch the cruise scan direction		

Call #57 preset	Start Pattern 1
Call #58 preset	Start Pattern 2
Call #59 preset	Start Pattern 3
Call #60 preset	Start Pattern 4
Call #61 preset	Call cruise 1 (default number 1~16 preset)
Call #62 preset	Call cruise 2 (default number 17~32 preset)
Call #63 preset	Call cruise 3 (default number 33~48 preset)
Call #67preset	Change system to PAL
Call #68preset	Change system to NTSC

APPENDIX II Trouble Shooting

Troubles	Reason	Solution
No action when power on	<ol style="list-style-type: none">1. The power supply is not connected correctly.2. The fuse is broken.	<ol style="list-style-type: none">1. Correct the connection.2. Check the power supply LED power indicator.3. Replace the fuse.
Self-testing and image are normal but the dome is out of control	<ol style="list-style-type: none">1. The dome DIP switch setting is incorrect.2. RS485 cable is disconnected or reversed.3. The control device is not properly configured.	<ol style="list-style-type: none">1. Confirm DIP settings on camera power-up screen.2. Reset the DIP Switch according to the DIP switch chart.3. Check the wiring.4. Check the control device settings
Some function is out of control	<ol style="list-style-type: none">1. The RS485 communication signal is not balanced.2. The control protocol is not compatible.	<ol style="list-style-type: none">1. Connect 120Ω resistor to the RS485 line.2. Change the protocol type.
Unclear image	<ol style="list-style-type: none">1. The focus is in manual state.2. Digital Zoom is on and in full ratio (If applicable)3. Dome cover is dirty.	<ol style="list-style-type: none">1. Reset the focus mode to Auto.2. Cancel/reduce digital zoom.3. Clean the dome cover.
No night vision	<ol style="list-style-type: none">1. The camera is in Color mode.2. backlight on the top or back of the dome camera	<ol style="list-style-type: none">1. Reset the day/night function to Auto.2. Remove the direct light source.



The IR HD PTZ Camera gives you more of everything:

Faster movements, higher accuracy, HD video performance, and easier installation.